

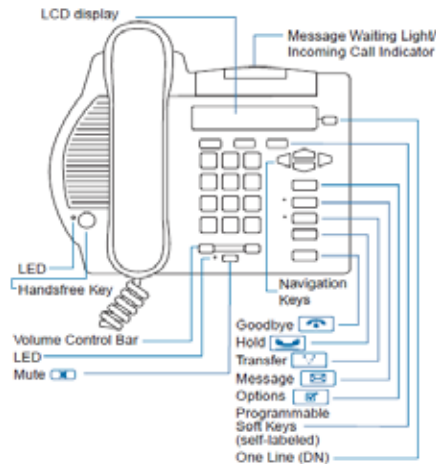

Nortel Phone 3902 (Phone With LCD Display)



MAKING A CALL:

Lift the **Handset** or press **Hands free** key  and enter the phone number.

1. Internal call: Dial the 4 digit extension
2. Local call: 9+External number followed by #
3. Emergency: 9+999 or 9+114
4. Toll Free: 9+800 + number

ANSWERING A CALL:

1. Lift the handset, or press Hands free key 

CLEARING A CALL:

1. Replace the handset or if on Hands free press the orange release button.

SOFT KEYS:

SOFT KEYS (e.g., **Call Wait, Forward, and Conference**) are located directly under the display. They enable the use of the functions displayed on the corresponding LCD tabs.

HOLD:

To place a call on hold

1. Press **Hold** .

To Return to Held Call

1. Press the green button next to extension of the held call.

CALL WAITING

During a call, you receive a second call

1. Call Wait soft key flashes.
2. Press it to take second call the first call is automatically put on hold.
3. Press Goodbye key (Orange key) to release the 2nd call.
4. Press the green key to take the original call.

INITIATING A CONFERENCE CALL:

A total of six parties (including yourself) can participate in a conference call.

1. While on a call, press **Conference** (Soft Key)
2. Enter phone number
3. Announce the party, select **Conference** again. You are in conference with three persons.

4. Go to step 1, 2 and 3 to add another party in the conference call.

FORWARDING YOUR CALLS TO ANOTHER EXTENSION:

1. Do not lift Handset, Press **Forward** (Soft Key)
2. Enter the number where your calls will be forwarded to
3. Press **Forward**.

FORWARD YOUR CALLS DIRECTLY TO VOICEMAIL:

1. Press Forward (Soft Key), then Dial **7410**
2. Press **Forward**.

TO CANCEL CALL FORWARDING:

1. Press **Forward** (Soft Key).

TRANSFERRING A CALL:

1. During the call, press **Transfer** (Soft Key).
2. Dial the extension
3. When answered, announce the caller and
4. Press the **Transfer** key.

LAST NUMBER REDIAL:

1. Lift Handset and press on the green button **OR** do not lift the handset ,press twice the green button

CALL PICK UP:

To pick up another ringing phone:

1. Lift handset or press hand free button on your phone
2. Press #50 + the ringing phone extension number.

CALL PILOT VOICEMAIL

MAILBOX NUMBER:

Your mailbox number is your **4-digit extension**.

INITIAL LOGIN/INITIALISE YOUR VOICEMAIL:

1. Lift Handset or Press Handsfree
2. Press the **Msgs** key  Press #
3. You are prompted to enter a password
4. Enter the default password which is 12 + your Extension number followed by #.
5. Enter new password (4digit) followed by #.
6. Re enter the new password again followed by #.(To confirm password).
7. You are now login into your mail box.
8. Follow prompt to read your message.

TO READ YOUR MAILBOX MESSAGES:

Note that if you have a message in your mailbox the red lamp will light up on your phone and the Msgs key will flash.

1. Lift Handset or Press Handsfree
2. Press the **Msgs** key  Press #
3. Enter your **Password** and press the # key.
4. Follow the prompts.

HOW TO CHANGE YOUR VOICEMAIL PASSWORD.

1. Lift Handset or Press Handsfree
2. Press the **Msgs** key  Press #
3. Enter your **Password** and press the # key.
4. Press 84
5. Follow the prompts.

FORWARDING A VOICEMAIL MESSAGE TO ANOTHER VOICE MAILBOX:

1. After listening to the message
2. Press digits **7 3** to forward the message.
3. Enter **4-digit extension** then press the # key for each number that you want the message to be sent to
4. then press the # key again when the last number has been entered.
5. Record a comment (to be heard by the recipient before the actual message.)
6. then Press the # key again
7. Press digits **7 9** to forward message.

PHONE LOCK:

1. To lock phone, dial #30 followed by your security password provided. Only internal calls are allowed after locking the phone.
2. To unlock phone, dial #31 followed by your security password.

FAULT REPORTING:

Dial 0 to report fault to operator
or send email to pabxsupport@uom.ac.mu

ADDITIONAL INFO:

1. Refer to the documentation CD provided with the M 3902 Telephone set for additional info about the telephone functionalities.
2. Revised version of this document may be released.

Updated on 05Feb2010 by RH